

MOC : M.S.
 SURFACE FINISH : PU ENAMEL SPRAY PAINTED
 COLOUR : GOLDEN YELLOW
 AUTO AND INCHING MODE LIFTING OPERATION.

LOCATION: PIT MOUNTED

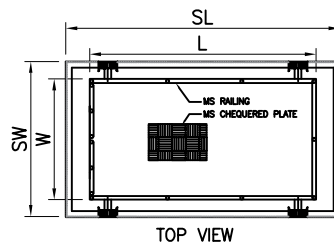

CAPACITY	C	1000 kg
PLATFORM LENGTH	L	2500 mm
PLATFORM WIDTH	W	1500 mm
MOTOR HP	M	7.5 HP
MIN HEIGHT	H1	1700 mm
MAXIMUM HEIGHT	H2	13700 mm
LIFT HEIGHT	H	12000 mm
RAILING HEIGHT	H3	900 mm
SUPER STRUCTURE HEIGHT	SH	14000 mm
SUPER STRUCTURE WIDTH	SW	2000 mm
SUPER STRUCTURE LENGTH	SL	3000 mm

NOTE

1. HYDRAULIC HOSE LENGTH FROM CYLINDER TO POWER PACK WILL BE 5 M
2. LIFTING SPEED : APPROXIMATE. 3M/MIN.
3. LOWERING SPEED - ADJUSTABLE
4. CHEQUERED PLATFORM: 4mm
5. POWER SUPPLY : 415 VAC (±10 %) , current 11A, 50 Hz (±5 %) , 3 phase
6. OPERATION : INCHING AND AUTO MODE BOTH

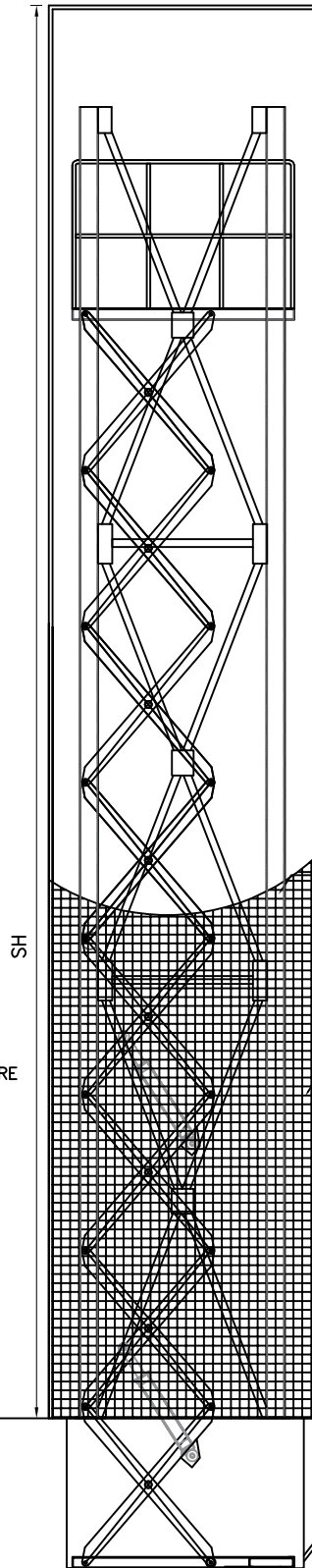
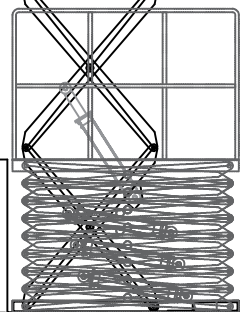
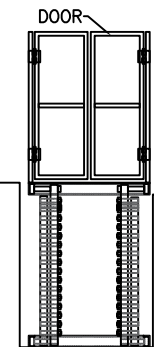
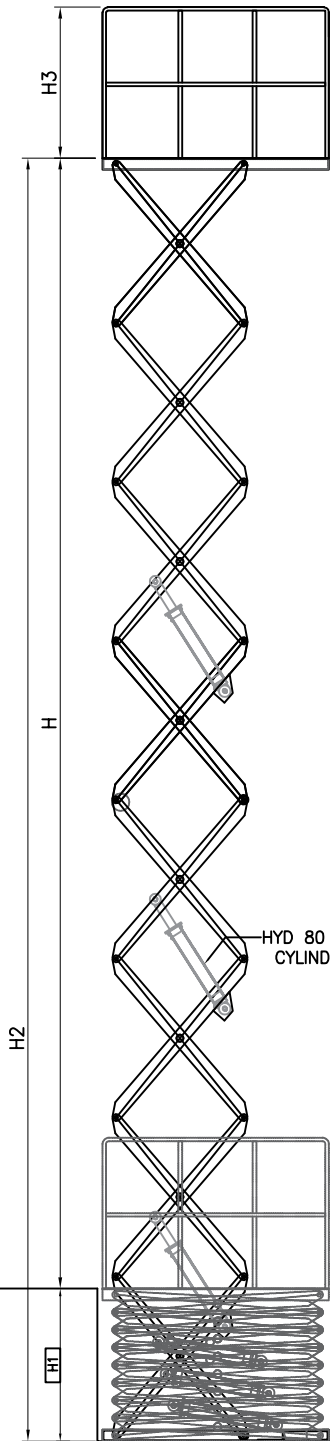

GUIDE
 WIRE MESH SUPERSTRUCTURE

POWER PACK POSITION IS AS PER CUSTOMER CONVENIENCE

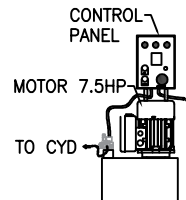

FRONT VIEW
 ALL ASSEMBLY WITHOUT SUPERSTRUCTURE

SIDE VIEW
 ALL ASSEMBLY WITHOUT SUPERSTRUCTURE

SIDE VIEW
 ALL ASSEMBLY WITH SUPERSTRUCTURE

ALL DIMENSIONS ARE IN MM

CUSTOMER:~ M/S COMMSCOPE INDIA PVT LTD			
PRODUCT:~ ELE HYD SCISSOR LIFT (STATIONARY)			
PROJECT:~3676_B		CAPACITY : 1000 KGS.	
COMP.FILE NO : GA DRAWING			
PROJECTION:~	SCALE:~ NTS	DATE	SIGN
		DRAWN 03.07.2020	RSG
		CHECKED 03.07.2020	ANIKET REV
		APPROVED 03.07.2020	PRATIK 00

JOIST-O-MECH
 (SINCE 1987)

THIS PRINT IS THE PROPERTY OF
 M/S JOIST-O-MECH
 RETURNED UPON REQUEST THIS PART MUST
 NOT BE SOLD TO ANY OTHER CONCERN.

SIZE	A4
SHEET	1 OF 1